

Plan View

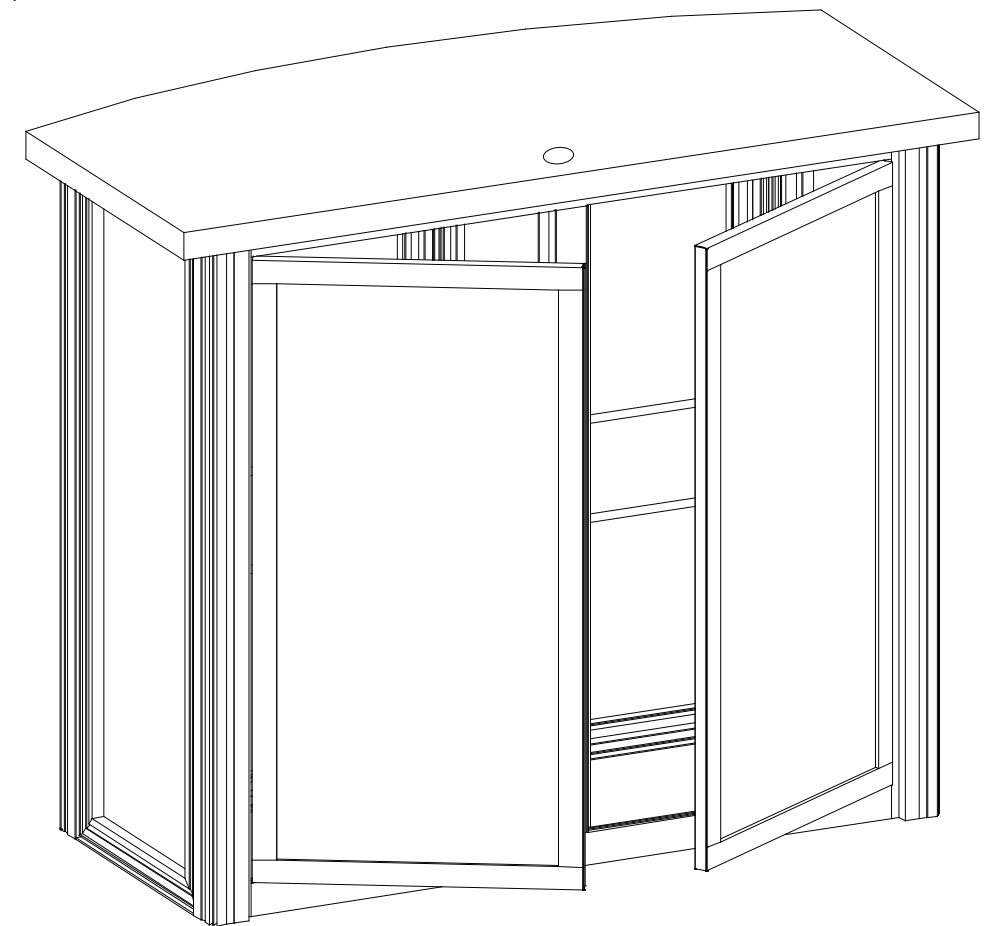

Back Side

## General Setup Instructions

- Read entire setup instruction manual prior to unpacking parts and pieces.
- The setup instructions are created specifically for this configuration.
- Setup instructions are laid out sequentially in steps, including exploded views with detailed explanation for assembly.

## Cleaning & Packing

- For Cleaning Metal, Plex, & Laminate Parts: Use a **MILD NON-ABRASIVE** cleanser and soft cloth/paper towel to clean all surfaces.
- Keep exhibit components away from heat and prolonged sun exposure. **Heat and UV exposure will warp and fade components.**
- Retain all provided Packing Materials. All provided packing materials are for ease of repacking & component protection.

## Disassembly

- For loss prevention, tighten all setscrews and locks during disassembly

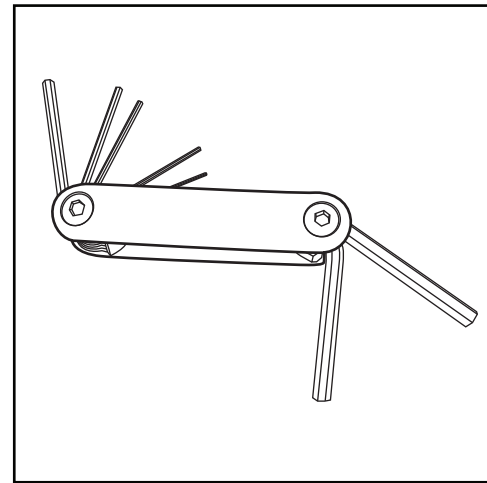

Hex Tool - Essential for Assembly

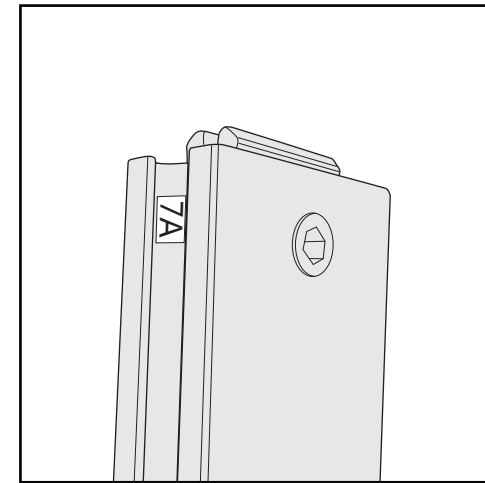

Part Identification - Numbering

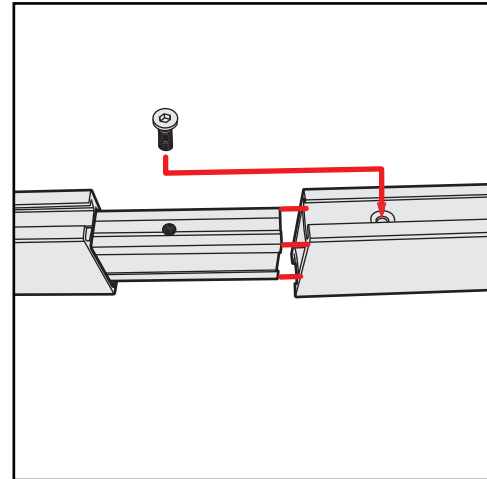

Spline Connection

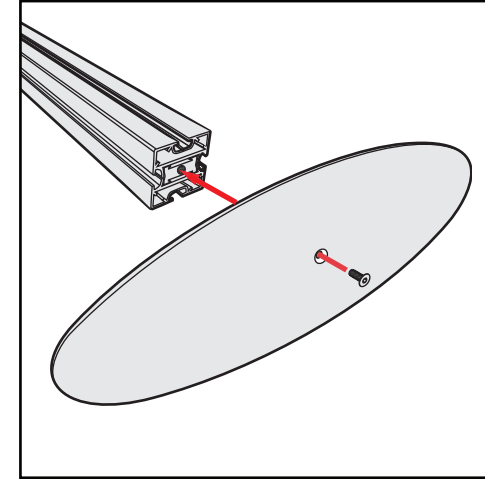

Base Plate & Extrusion Connection

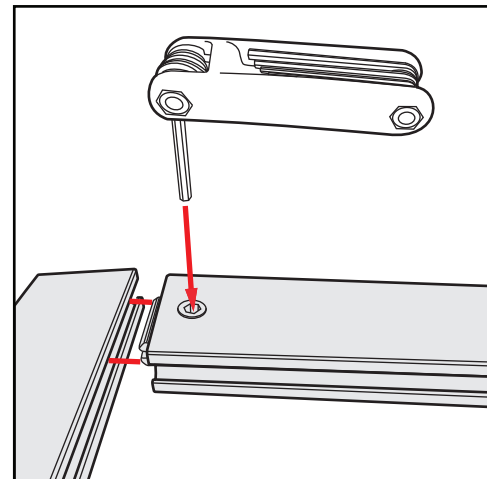

Extrusion & Lock Connection

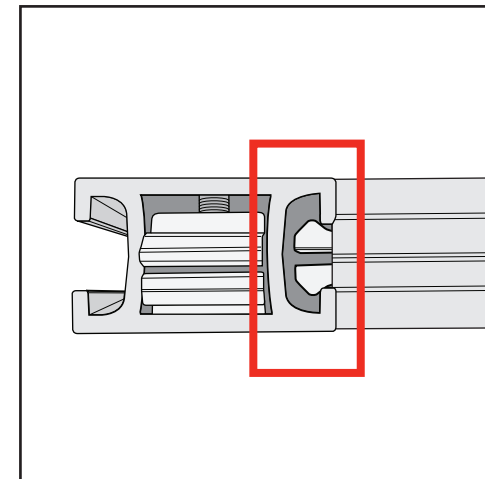

Engaged Lock



# WARNING



DO NOT USE POWER TOOLS



LADDERS OR LIFTS  
MAY BE REQUIRED



ALL CONNECTIONS MUST  
BE TIGHTLY SECURED

## Side-by-Side Assembly

- 1) Frames: Place frames side-by-side with one higher than the other, then slide panel down to lock panels securely together.
- 2) Corner Connectors: Repeat Step 1 for installing corner connectors to frames.

## Side-by-Side Disassembly

- 1) Pull pin lock outwards to disengage.
- 2) Pull frames upward and apart at the same time to detach.

Assembly

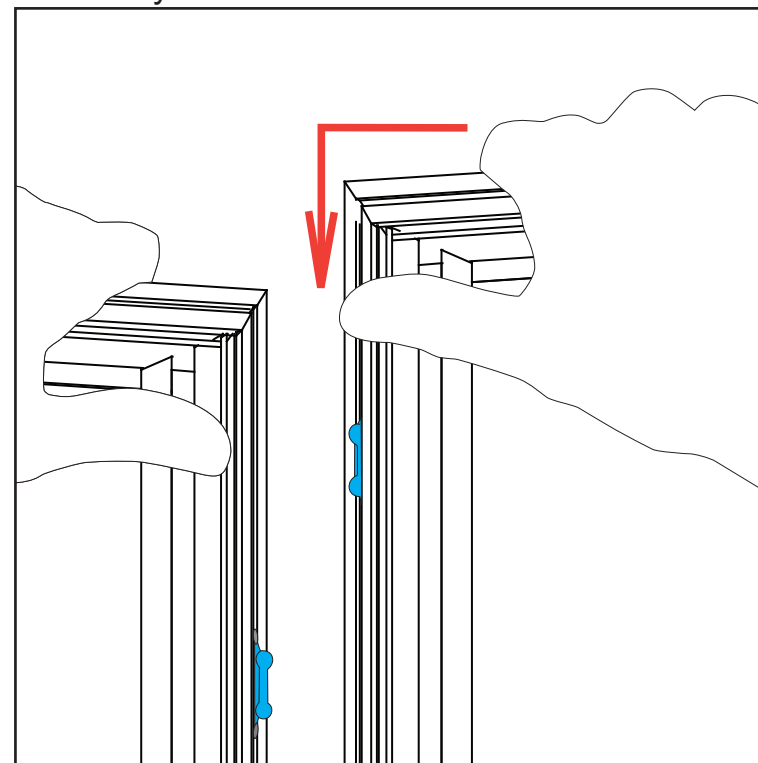

Assembly Cont'd

Push pin lock into hole of connecting frame.  
Note: Block of pin lock will secure in groove.

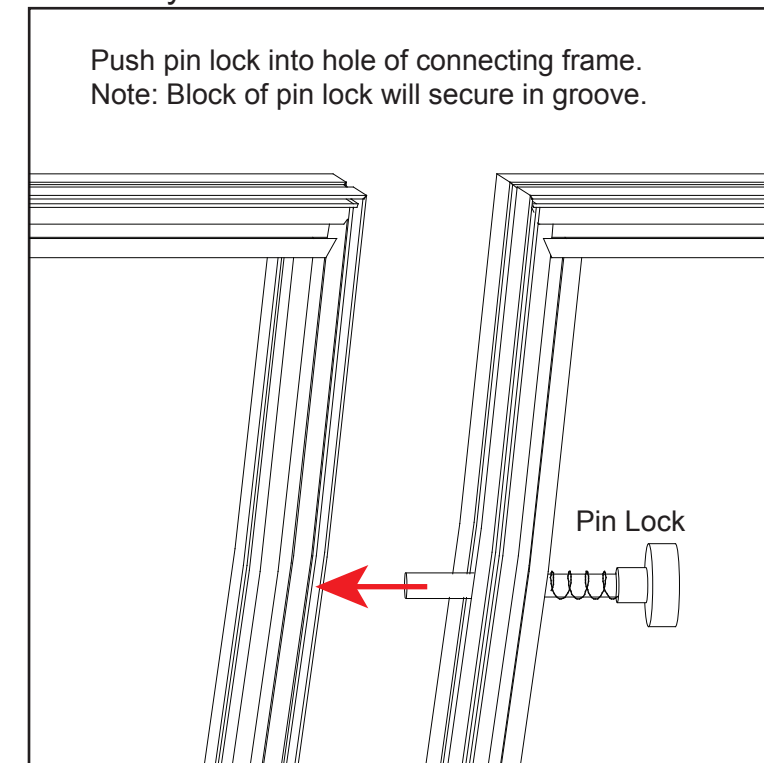

Corner Connector

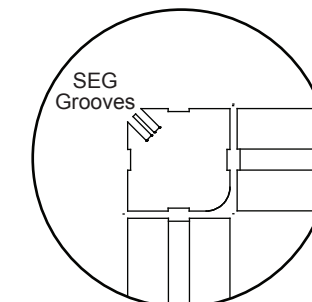

Top View

Note: Orientation of Corner Connector may change.

## Stacking Assembly

- 1) Place one horizontal frame on top of the other, lining up the center grooves.
- 2) Turn stacking lock clockwise to tighten into place. Repeat for each lock.

## Stacking Disassembly

- 1) Turn the stacking lock counter-clockwise to loosen.
- 2) The whole spring on the stacking lock should be in view to release each frame. The disengaged spring should release the stacking lock. If not, keep turning the stacking lock until it disengages.

Stacking

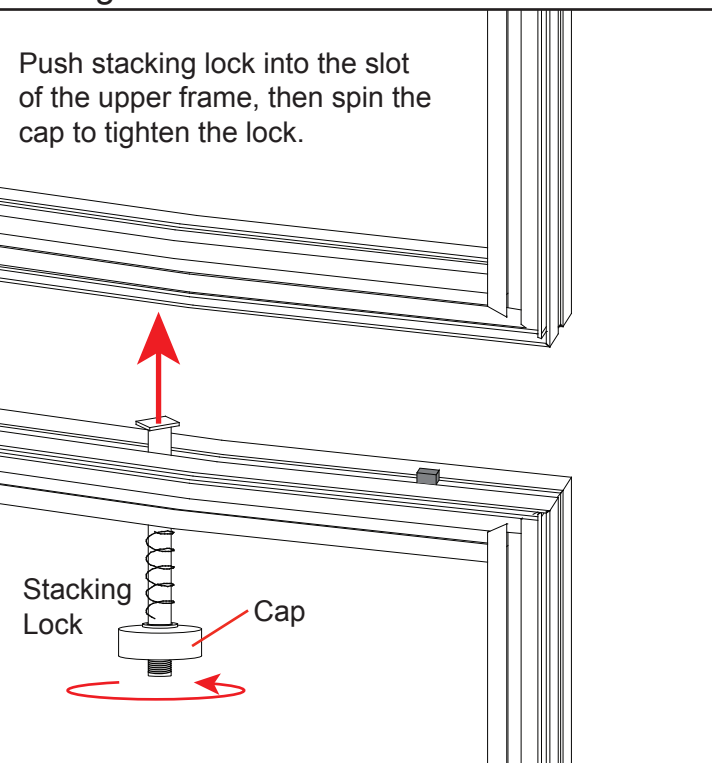

Unstacking

Disengage the stacking lock by spinning the cap counter clockwise and pulling down.

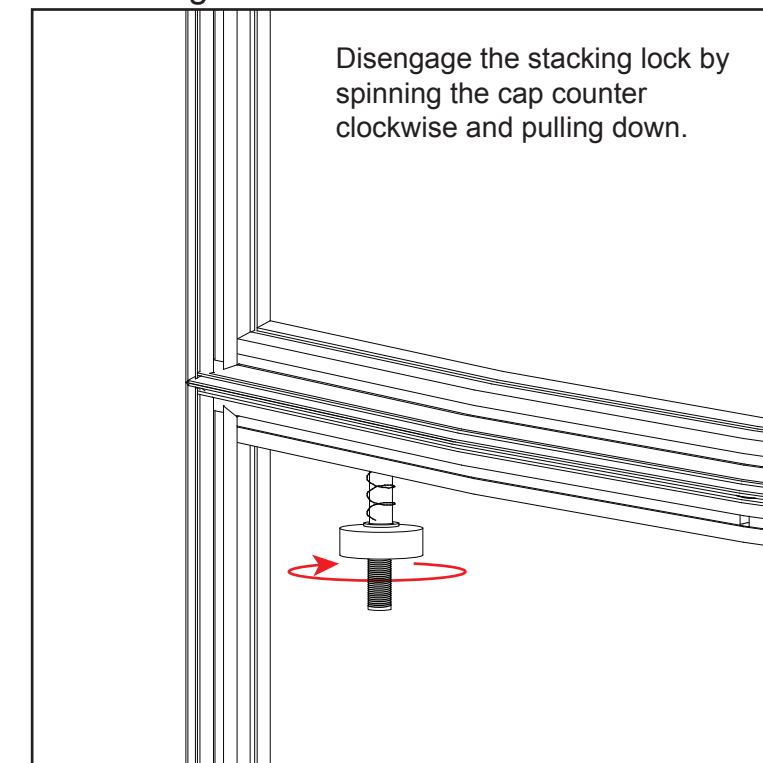

Item	Qty.	Description
1	1	38" h Gravitee Corner Post w/ Door Attachment
2	1	14.125" w x 38" h Gravitee Panel Frame
3	1	38" h Gravitee Corner Post
4	1	19" w x 38" h Gravitee Panel Frame
5	1	19" w x 38" h Gravitee Panel Frame
6	1	38" h Gravitee Corner Post
7	1	14.125" w x 38" h Gravitee Panel Frame
8	1	38" h Gravitee Corner Post w/ Door Attachment
9/9A	1/1	37.0945" w Z45 Horizontal Extrusion
10	1	34.4173" h Z45 Vertical Extrusion

- Steps:
- 1) Assemble Gravitee panels and posts in numerical order. See Gravitee Panel Assembly sheet for details.
  - 2) Attach horizontal extrusions [9] & [9A] between posts [1] & [8].
  - 3) Connect vertical [10] between horizontals [9,9A].
  - 4) Install Cabinet Doors. See **Door Attachment** detail.

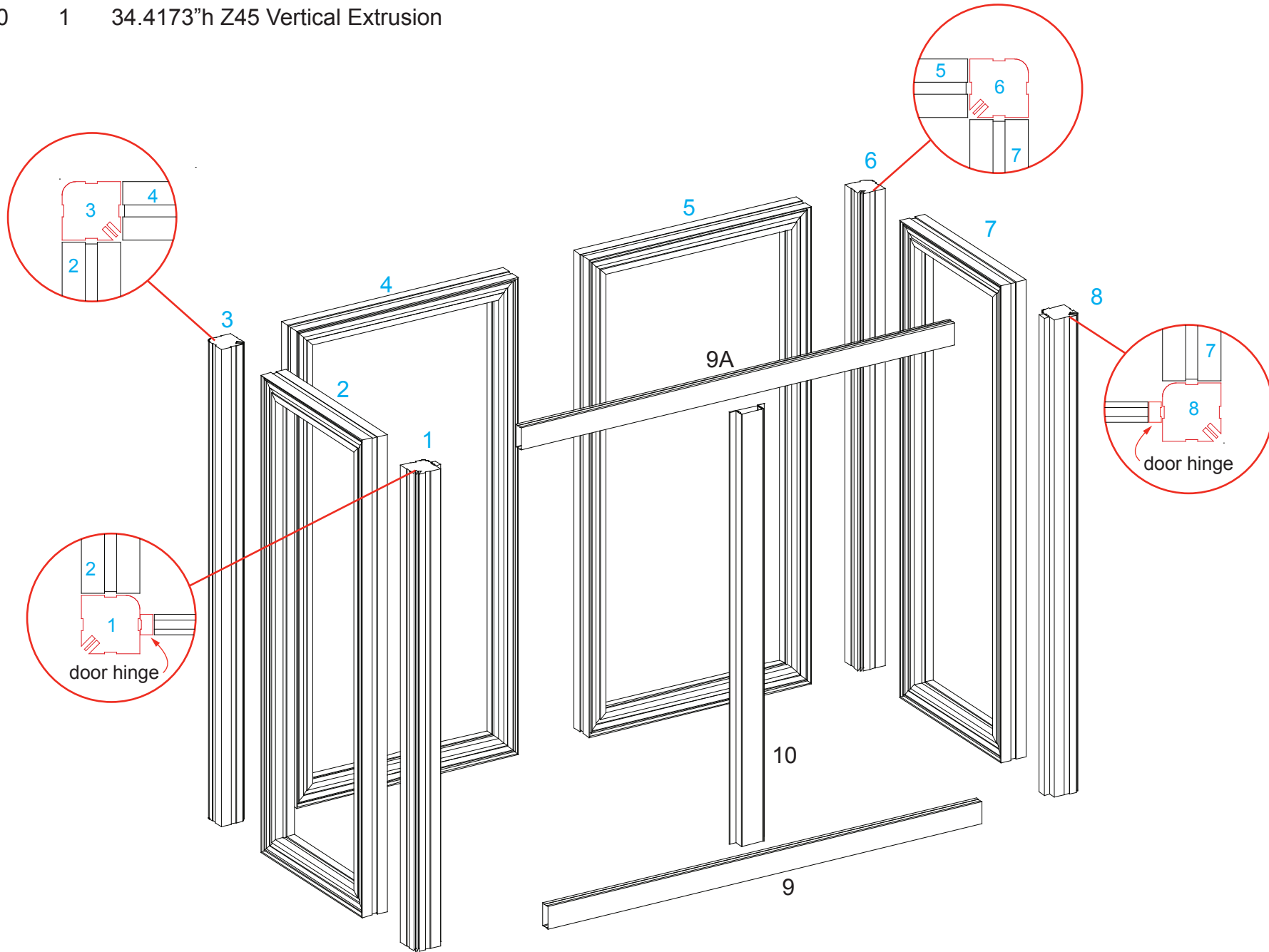
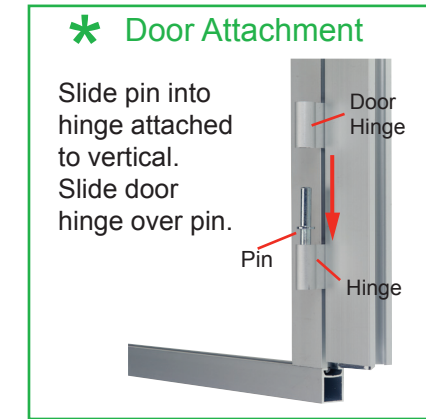

BACK SIDE

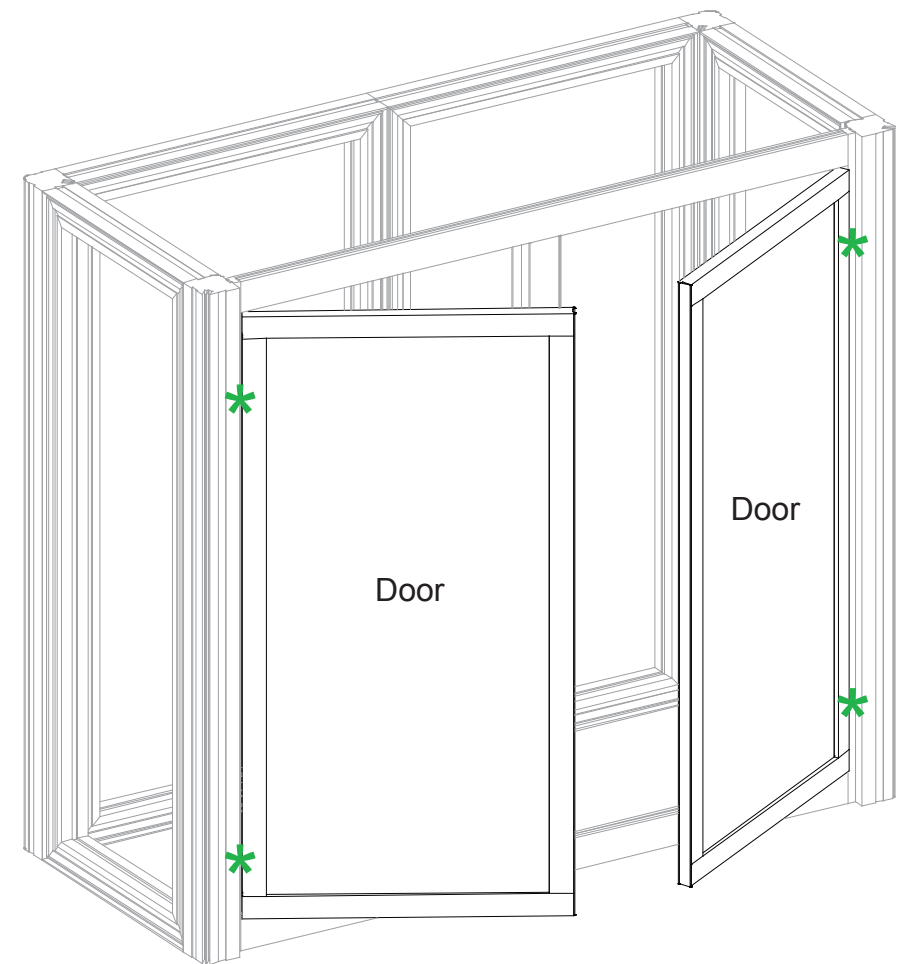

BACK SIDE



Top View

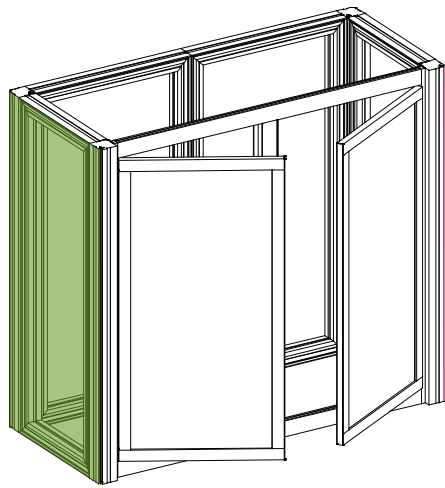

Back View

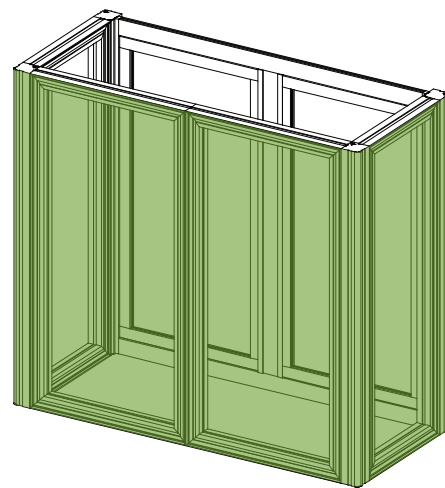

Front View

Steps:

- 1) Wrap **SEG Graphic** around front & sides of counter.  
See SEG Graphic Installation detail.
- 2) Attach shelf supports to **Velcro**, then place shelf on top of supports.
- 3) Place counter top on assembly. See **Counter Top Attachment** detail.

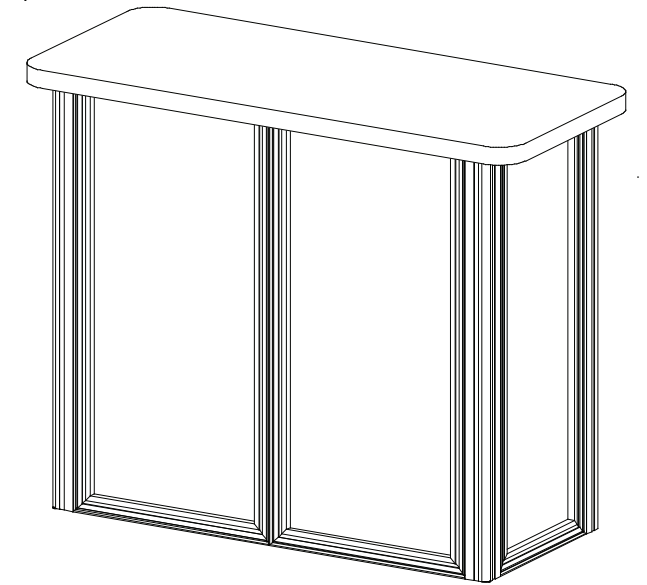

Completed Assembly

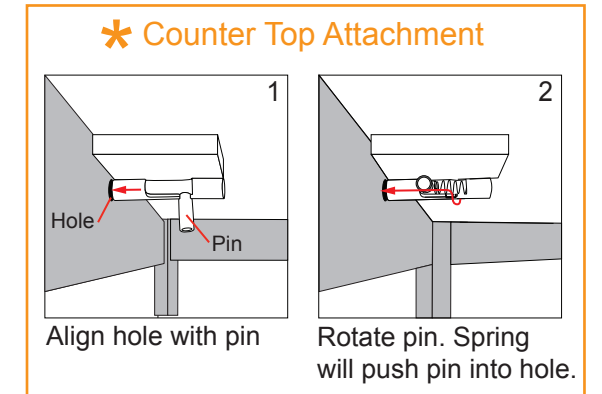
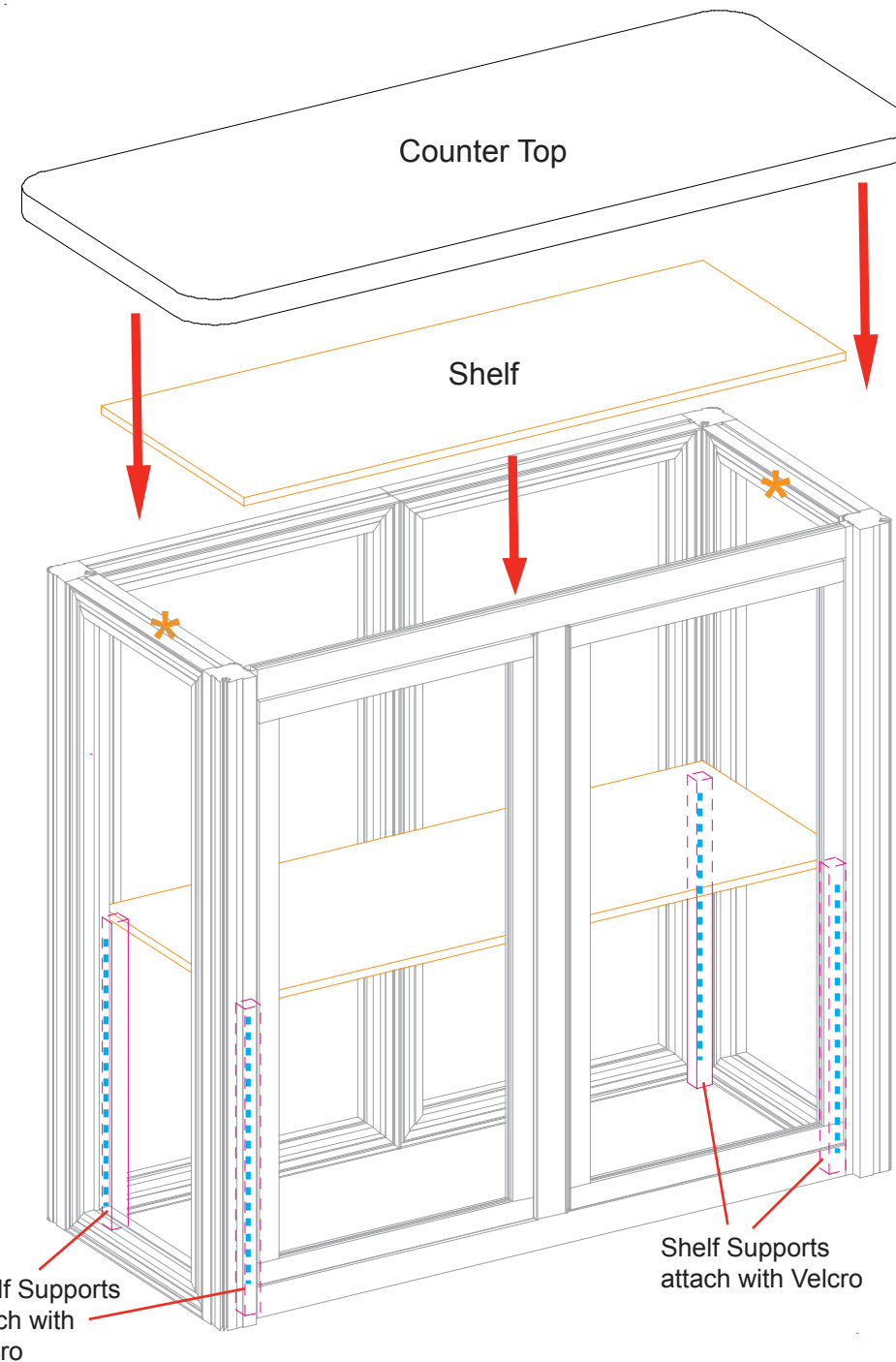

**SEG Graphic Installation**

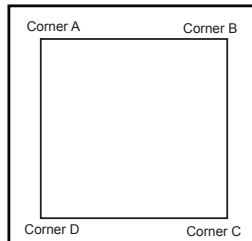

It is important to first insert graphic into each alternate corner then to the sides of the frame. If this is not done, graphic will not fit into the frame correctly.

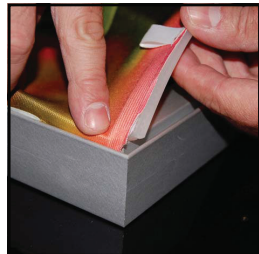

**Step 1**  
Insert corner A. Turn edge of graphic so silicon welt is perpendicular to face of graphic. Insert narrow side of welt with fabric to outside into the channel. Repeat for other side of this corner.



**Step 2**  
Repeat Step 1 for opposite corner C, then insert corner D, to complete the installation of the corners.



**Step 3**  
Once all corners are inserted, press one silicon edge into channel from corners and work toward the center. Make sure welt is fully inserted into channel. Continue until all sides are done. Smooth out edges of graphic.

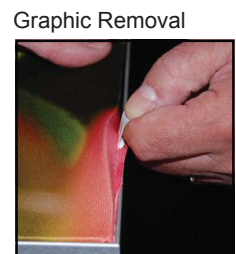

To remove the graphic from the frame, locate the fabric pull tab. Gently pull up on the tab to remove the fabric.

### Top View of Each Level

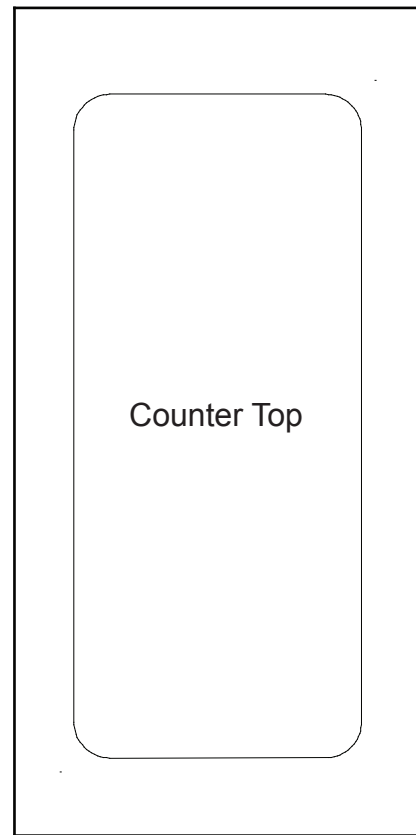

Level 1

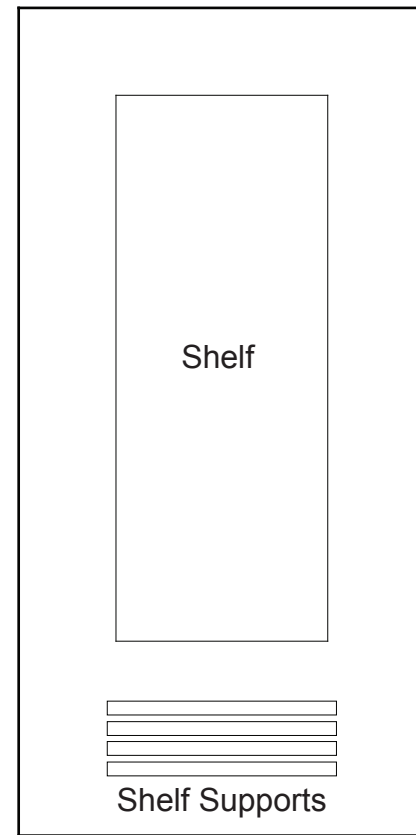

Level 2

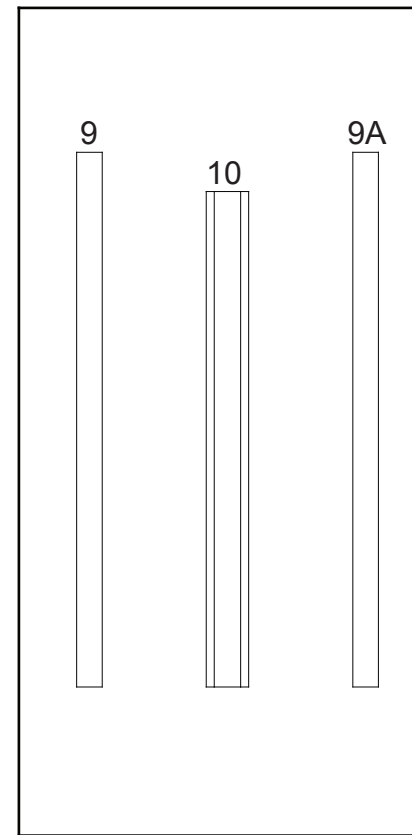

Level 3

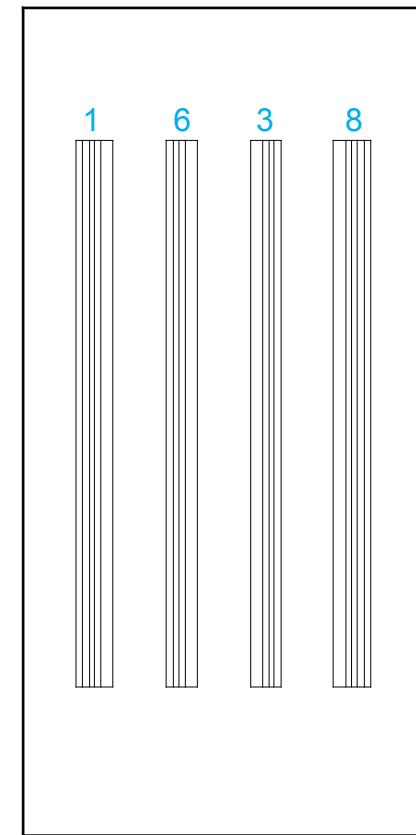

Level 4

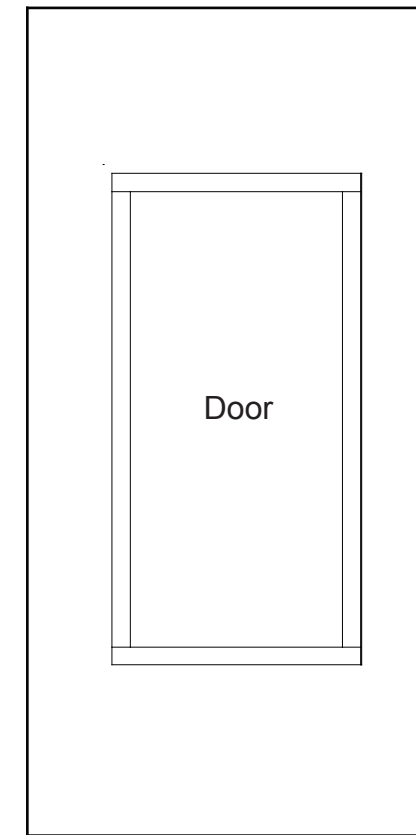

Level 5

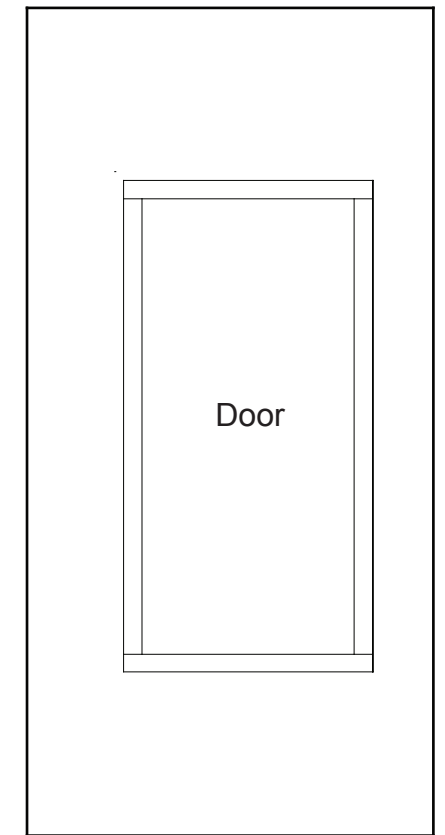

Level 6

### Top View of Each Level

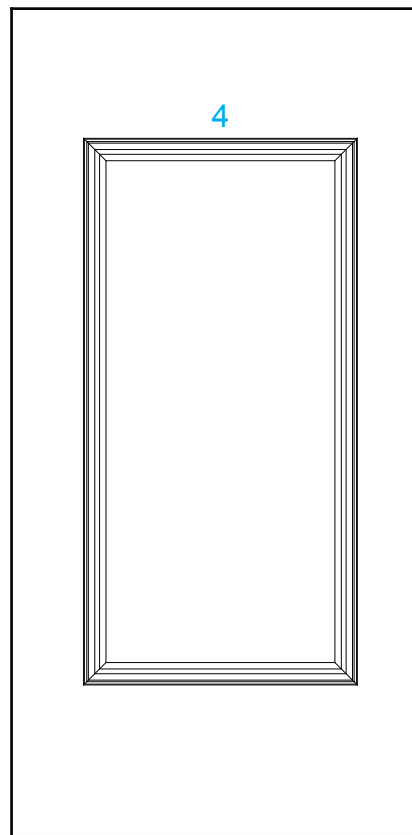

Level 1

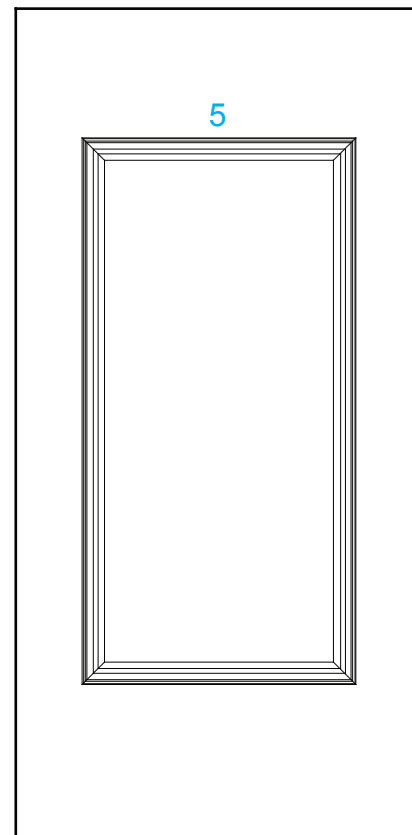

Level 2

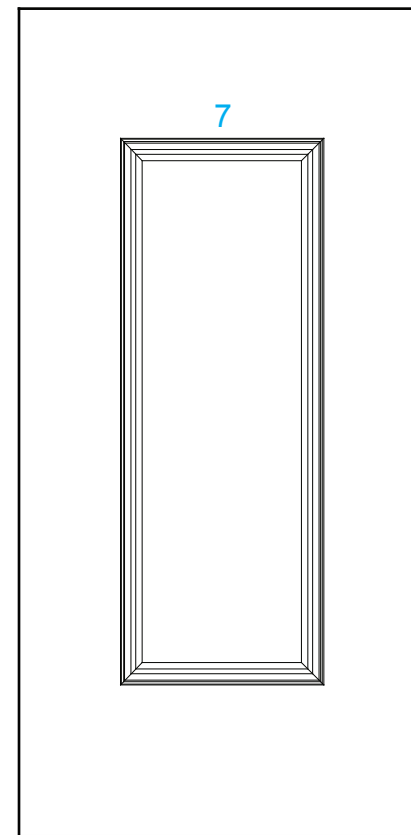

Level 3

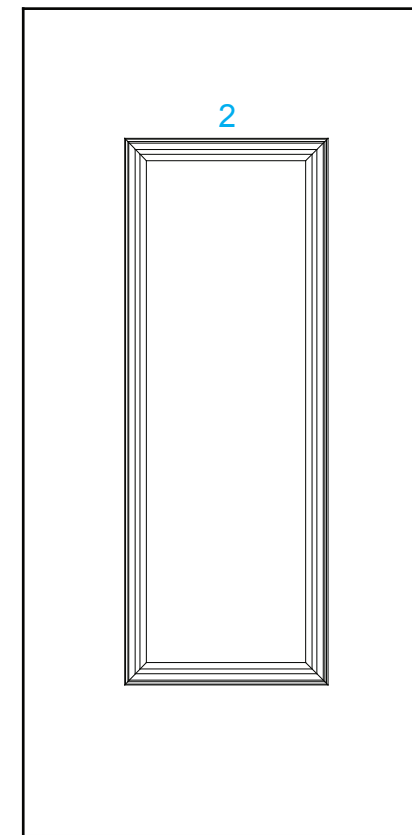

Level 4